

EN - Instructions for installation of home switches - DSR in RETRO design

Safety during installation:

The switch is designed for currents up to 16 A and voltage 250 V AC. The installation therefore needs to be carried out by a qualified electrician. Before starting the installation, always disconnect the power supply.

Installation of switches

1. When installing the switches the following conditions must be emphasized:

- wiring box for switches must be installed flush with the plaster
- in case of a problem with "drowned" wiring box it is necessary to use spacer (distance) rings VK1 and VK2, thereby preventing deformation of the metal frame of the device while tightening the screws
- fastening in the installation box is made through the metal frame of the switch with two screws $\varnothing 3$ mm
- for installation of multiple sets of the device it is necessary to use multiple boxes with a pitch of 71 mm
- switches in arrangement 1, 2, 5, 6, 1/0 can be mounted in the wiring box with a min. depth of about 42 mm and switch in arrangement 7 and 3 gang 1way switch in the wiring boxes of a min. depth of about 60 mm

2. Connecting the switch:

- the switches are designed to connect cables from $1,5 \text{ mm}^2$ to $2,5 \text{ mm}^2$
- strip wires in total length of max. 10 mm
- connect the wires according to wiring diagrams - see wiring diagram
- tighten the wires with a torque of 1 Nm use no. 15 Torx screwdriver for tightening
- before mounting the switch to the wiring box, the proper and firm fastening of the wires in terminals of the device must be checked and loose wires tightened

3. Completion of the switch installation:

- mount the switch in the OFF position (arrangement 1, 2, 5, 1/0 and 3 gang 1 way switch) – the switch is placed in the wiring box so that the lock pin of the switch is in the horizontal position (Fig. 1)
- place a frame (ceramic, wood, glass, concrete) on the metal frame of the device and lock it with screws (Fig. 2 and Fig. 3). With the glass frame is handle connected together. When using ceramic frame, tighten screws with a torque of 0,05 Nm – this prevents cracking of the frame due to its brittleness

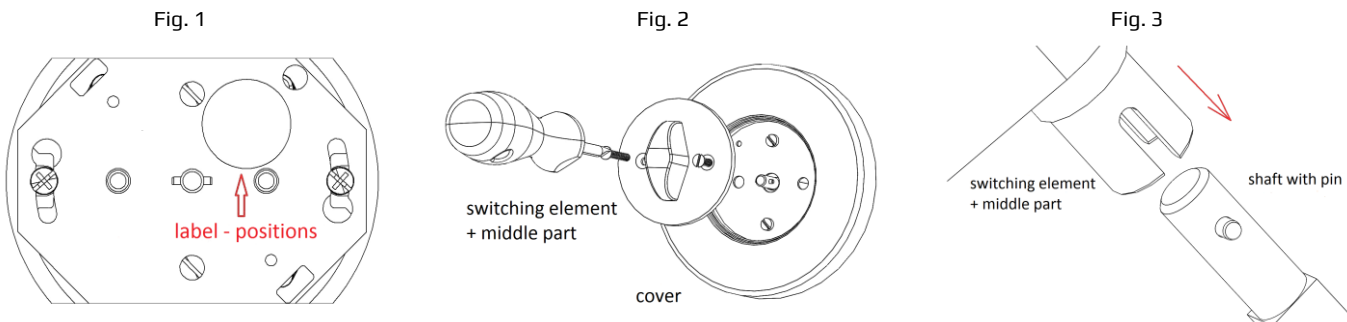

Wiring diagrams:

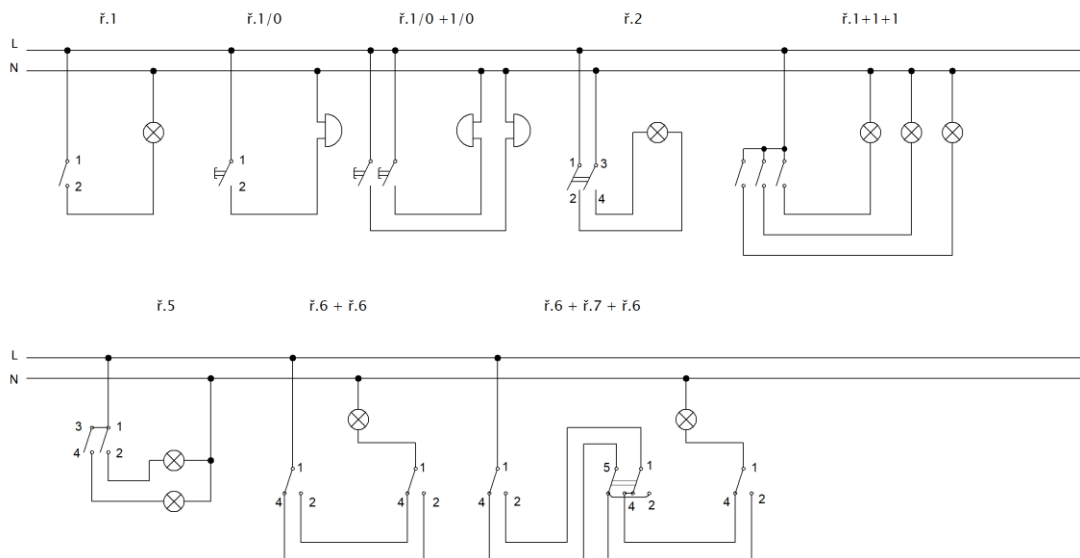

Orientation of positions – description:

0 – OFF 1 – ON (light 1) 2 – ON (light 2) 3 – ON (light 3)

Arrangement no. 1, 2

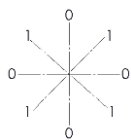

Arrangement no. 5

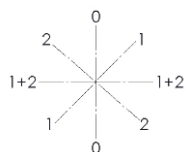

Arrangement no. 6, 7

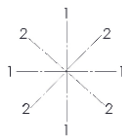

Arrangement 1/0

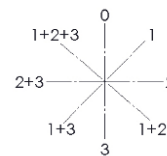

3 gang 1 way switch

**Maintenance:**

The switch device does not require any maintenance!

Covers of the devices must never be wiped or washed by abrasive cleaning cloths and no aggressive chemicals (petrol, acetone, etc.) may be used on them.

EN - Instructions for installation of a single home socket schuko – DSR in RETRO design**Safety during installation:**

The socket is designed for currents up to 16 A and voltage 250 VAC. The installation therefore needs to be carried out by a qualified electrician. Before starting the installation, always disconnect the power supply.

1. When installing the socket the following conditions must be emphasized:

- wiring box for sockets must be installed flush with the plaster
- in case of a problem with “drowned” wiring box it is necessary to use spacer (distance) rings VK1 and VK2, thereby preventing deformation of the metal frame of the device while tightening the screws
- fastening in the installation box is made through the metal frame of the socket with two screws \varnothing 3 mm
- for installation of multiple sets of the device it is necessary to use multiple boxes with a pitch of 71 mm
- we recommend placing sockets in the wiring boxes with a min. depth of 40 mm

2. Connecting the socket:

- terminal is suitable for connecting wire with a diameter of 2,5 mm²
- strip wires in total length of max. 10 mm
- before mounting the switch in the wiring box, the proper and firm fastening of the wires in terminals of the device must be checked and loose wires tightened

3. Completion of the socket installation:

- mount the socket in the wiring box (Fig. 1)
- place a frame (ceramic, wood, glass, concrete) on the metal frame of the socket and lock it with the socket cover using screws (Fig. 2). In case of ceramic frame, tighten screws with a torque of 0,05 Nm – this prevents cracking of the frame due to its brittleness
- when using the ceramic frame, it is necessary to fit a gasket on the socket cover (Fig. 3), by glass frame gasket do not use.

Fig. 1

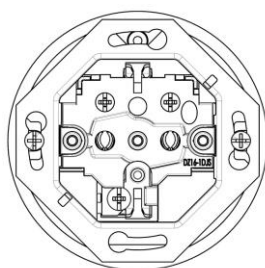
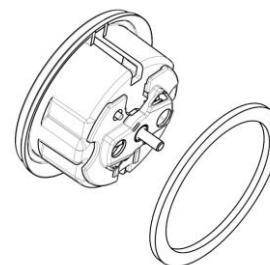

Fig. 2

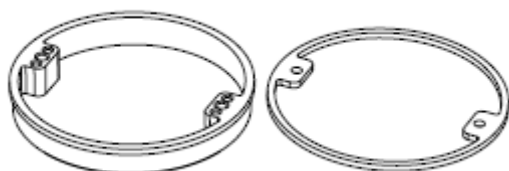

Fig. 3



VK1

VK2



Warning: Do not use the damaged or damaged device and secure it against use. Disassembly must be entrusted to a person with a corresponding electrotechnical qualifications. If the device is not fitted with visual parts, must not be put into a voltage state.

This product does not contain any hazardous substances. At the end of its life, it must be handled in terms of the applicable Waste Act, as amended.